

Standard Deck Attachment Details:

F-Deck

36-4 Pattern

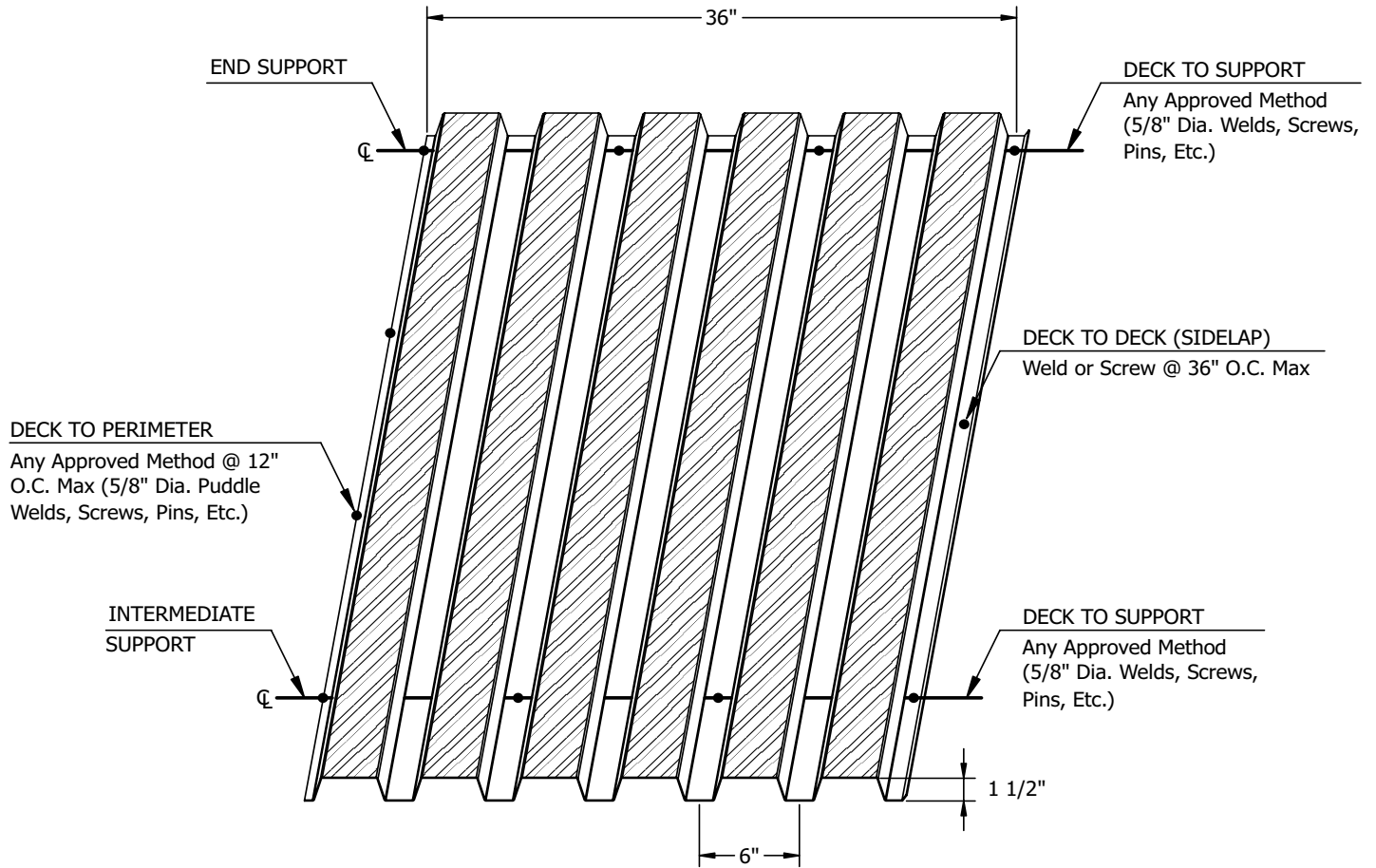

Notes:

The following **CSM Products & Services** standard attachment pattern has been provided as a minimum recommendation for the product specified. The anchorage system of roof deck units to supporting members consists of Deck to Support, Deck to Deck (Sidelap) and Deck to Perimeter. When project specifications, specific design loads, or local building codes require more stringent patterns than those on our standard details, then the more restrictive requirements shall govern. The project Engineer of Record should review the standard attachment requirements in order to verify conformance with project specifications, design loads, and local building code requirements. For additional information or attachment pattern configurations contact **CSM Products & Services**.

The attachment patterns stated are applicable for use with various fastener types. Typical fastener types include arc puddle welds, screws and pins. Please refer to our diaphragm shear capacity tables and uplift capacity tables for the product specified to confirm strength characteristics of the specified fastener type and attachment pattern.

CSM Products & Services recommends the use of weld washers for support attachments with deck units less than .028" (0.71 mm) thick (not required for 22 gauge). Due to the difficulty of side



lap welding on 22 gauge and lighter metal decks, **CSM Products & Services** recommends these thicknesses be attached with side lap screws.

Contact CSM Products & Solutions

1-800-553-0373

www.csmproductsonline.com