

# Installation Guide: CSM620 FRP Gutter & Downspout

## Manufacturer's Assistance

These instructions are intended for the CSM620 Fiberglass Gutter and Downspout System. For further assistance, please contact:

### Commercial Siding & Maintenance

8660 Lambright Road, Houston, Texas 77075

Tel: 800-229-4276 Fax: 713-991-4747

## Material Handling and Storage

1. Inspect materials upon delivery. If damage is found, promptly advise both freight carrier and Commercial Siding. Note damage on carrier's receiving ticket.
2. When lifting materials, use spreader bars. Do not use wire slings unless panels are protected.
3. Protect materials from surface cuts, impacts, and abrasions.
4. **FRP materials cannot be reshaped by use of external force such as hammering or extreme bending.**
5. To cut materials, use a circular saw with an abrasive or fine-toothed blade. A dust mask is recommended.
6. While in storage, keep materials covered, off the ground high enough to allow for air circulation, and above standing water.
7. Do not stack or store other materials on top of unprotected units. Support products so that they cannot twist or distort.

## Gutter Installation (for Existing Buildings)

### Prep and Assembly

*CSM620 gutter box and flange can be assembled on the ground and then attached to the building; or the flange can be attached to the building with the gutter box attachment to follow.*

1. Prepare part surfaces to be bonded per Bonding Instructions.
2. Locate placement for gutter, outlets, and downspout installation and measure full run. Cut parts as needed.
3. Follow the Bonding Instructions and assemble system into manageable units (including splices, end caps, etc.). Allow joints and assemblies to cure.
4. Cut 3 3/4" square holes for downspout outlets at correct locations in gutter box. Place outlet through the hole and bond outlet to gutter. Allow joint to cure.

### Installing Gutter

1. Place gutter flange so its outer edge is 1 1/2" to 2 1/2" inside of the roof panel overhang. Attach gutter flange securely to the building. If the gutter flange is placed under existing roof panels, the panel fasteners must pass through the gutter flange to be attached to structural supports.
2. Before attaching the gutter box, apply adhesive to either the flange or box. Holding the gutter box in the same line as the flange, place the round gutter lip into the flange hook. Roll the gutter box down until it locks into place and into position (see detail on back). A self-tapping screw (placed into the joint every few feet) will hold the joint while it cures.
3. Make sure the gutter hangs level by shimming or adjusting the gutter flange. If the distance between the gutter box and siding is more than 2", install wood blocking between siding and gutter.
4. *As required for high snow or large water volume conditions, install gutter straps 5' on center. The straps would be field bent to match the roof slope. (See Typical Installation detail).*

### Installing Downspouts

1. Apply adhesive to the outside of the downspout outlet.
2. To attach the downspout tube and outlet, push the downspout onto the outlet with sufficient pressure for proper fitting and bonding of the two pieces. Tack the joint with fasteners until it

cures (see Bonding notes).

3. Apply adhesive to the outside of the downspout splice.
4. To connect downspout tubes together, push the downspout tube onto the splice part with sufficient pressure for proper fitting and bonding of the parts. Tack the joint with fasteners until it cures (see Bonding notes).
5. Fasten the stainless steel downspout straps to the building with either self-tapping screws (into steel supports) or with SB2 grommets (into wall panels).

## Installation on New Buildings

*Follow the steps listed under "Installation for Existing Buildings" with these exceptions:*

1. Install the gutter system after siding installation but before roof sheets are fastened down at the eaves.
2. Tack the gutter flange to the eave structural supports (eave strut or roof purlin) with stainless steel pan head or tapered screws.
3. When roof sheets are installed and fastened to the eave support, make sure the fasteners pass through the gutter flange and are secured to the building structure.

## Bonding Instructions

1. Prepare surfaces for bonding and remove surface film by sanding with 120 grit sandpaper. Surfaces are ready when the surface gloss is removed.
2. Clean surface thoroughly using a clean rag dampened with a solvent such as acetone or methyl alcohol. Some gutter parts may have a paint coating, which could be damaged by some solvents. Test the solvent or cleaner on a hidden area before using it on a visible area.
3. Mix the two-part adhesive according to the manufacturers directions. Always use adequate safety devices such as rubber gloves, face mask, etc.
4. Spread a thin film of adhesive on both surfaces to be joined. Cover any glass fibers that are exposed.
5. Hold freshly bonded joints in position with clamps or weights until the adhesive cures. The gutter system should not be exposed to its design load until bonded joints have cured a minimum of 48 hours at 70 degrees F. If temperature is cooler, bonds will need a longer curing time.
6. Self-tapping screws, bolts, or rivets can be used to hold freshly bonded joints in place during curing. These fasteners can be removed after curing or left in place. Use sharp or carbide tipped drill bits under moderate pressure when drilling into FRP. *The epoxy kit will bond approximately 10 joints or 50 LF of gutter box to gutter flange.*

## Fastening Gutter to Structural Members

1. Fiberglass materials are typically fastened with 300 or 316 stainless steel or monel. These metals are softer than carbon steel and require more care for installation.
2. Type A fasteners can be used when fastening CSM620 gutter to FRP beams.
3. If gutter system is being installed with FRP panels or beams, request Installation Instructions from panel/beam manufacturer.

## Cleaning and Repair

1. Clean material with soap and water first. If this does not work, some solvents can be used to clean spills or stains on fiberglass. However, solvents should be used sparingly and only if necessary.
2. Minor damage to FRP materials can be patched with a FRP repair kit. Materials with other damage should be replaced.

### Typical Installation

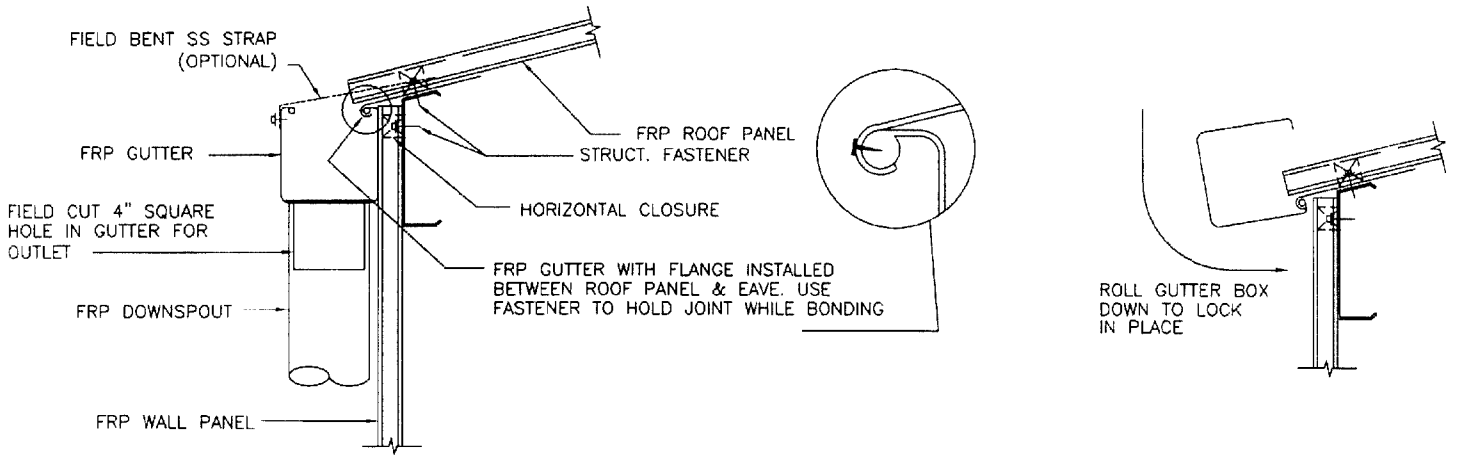

### Exploded View of Gutter System

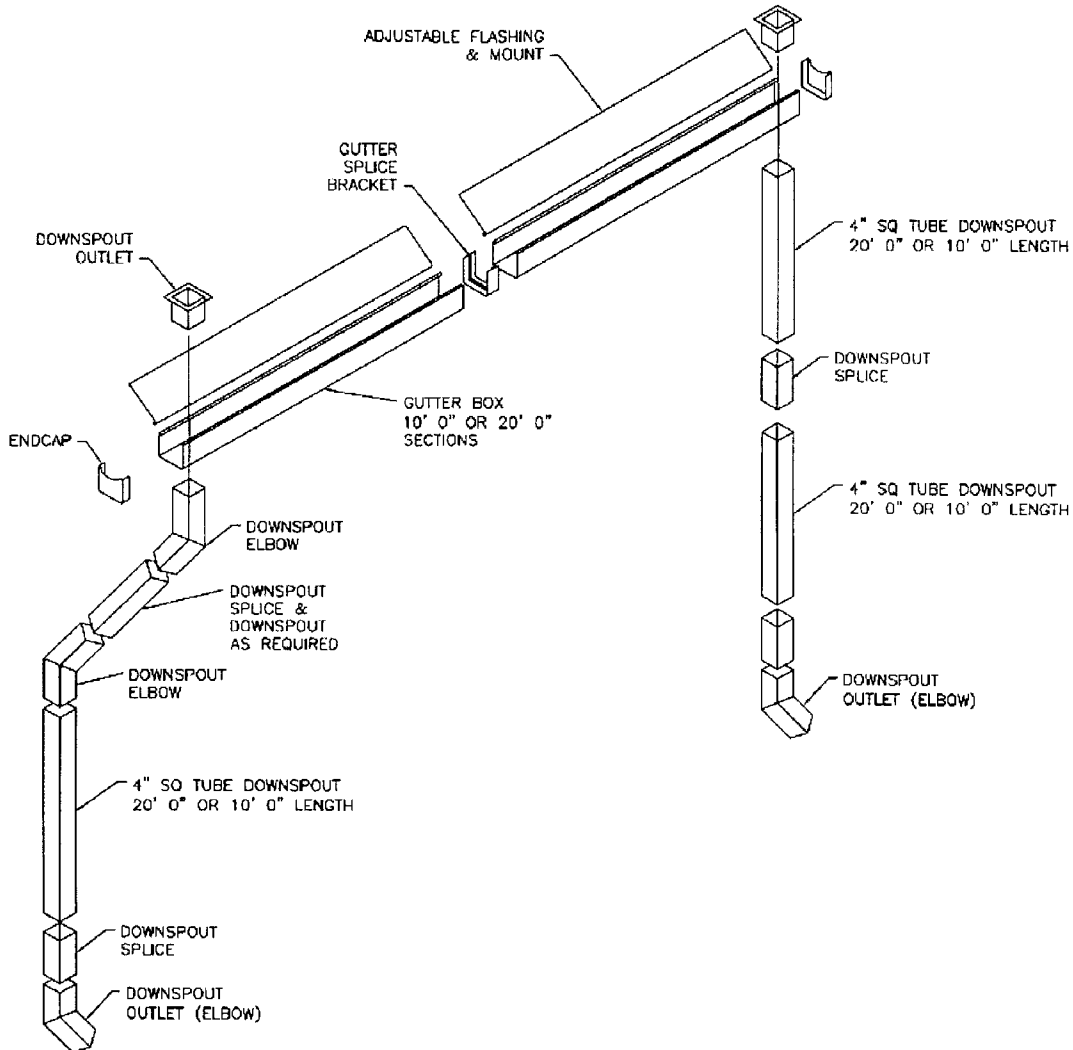

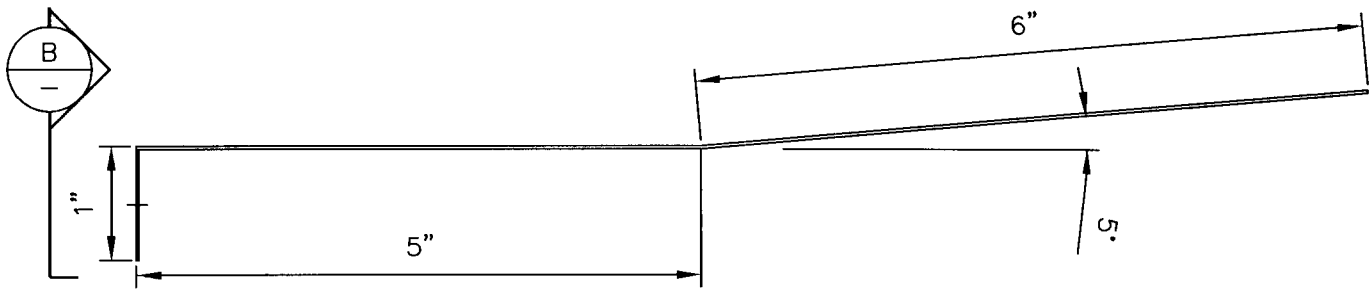
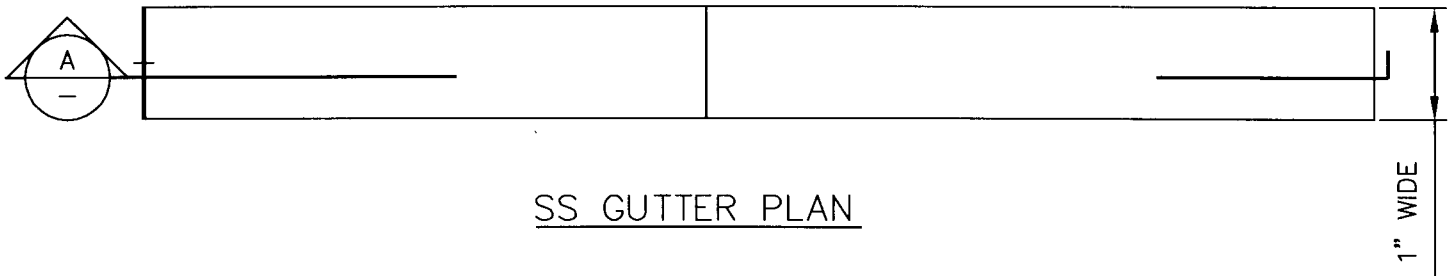

SECTION A  
—

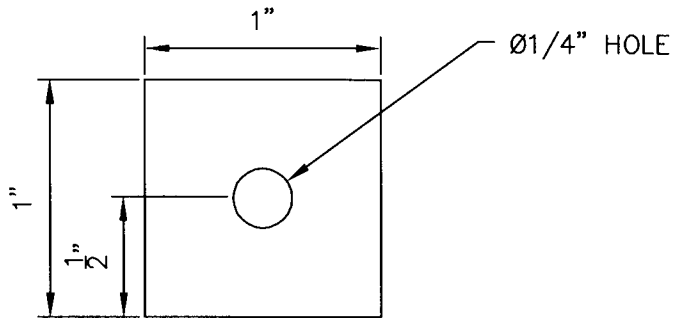

SECTION B  
—

**NOTES:**

1. MATERIAL: 304SS 24 Gauge
2. RESIN SYSTEM: N/A
3. COLOR: N/A
4. TOLERANCE: (U.N.O.)  $\pm 1/16"$
5. BILL PG. NO.:

PC. MK.: SS GUTTER STRAP  
TOTAL QTY.:

REVISIONS

REV.	DATE	DESCRIPTION	BY

ISSUED FOR

APPROVAL		
FABRICATION		
RECORD		



**Commercial Siding & Maintenance**

THIS DOCUMENT IN DESIGN AND DETAIL IS THE PROPERTY OF COMMERCIAL SIDING & MAINTENANCE; ANY USE OR DISCLOSURE WITHOUT THE WRITTEN PERMISSION OF COMMERCIAL SIDING IS STRICTLY FORBIDDEN.

DRAWING #	SS GUTTER STRAP	DWN BY:	JL	CHK BY:	JL	DATE:	7/20/6	REV.	0	CONTRACT #	
-----------	-----------------	---------	----	---------	----	-------	--------	------	---	------------	--

PRODUCT: SS GUTTER STRAP

NAME: SS GUTTER STRAP

LOCATION: